



SPECIAL FUNCTIONALITY IN E³.eCheck

- Circuit functional analysis
- Current checking
- Current direction indicator
- Voltage drop analysis
- Fuse sizing
- Voltage supply generation
- Load checking
- Temperature rating
- Automatic device state change
- Visual and audible feedback
- Error navigation tool
- Hierarchical design
- Multi-symbol components
- Multi-sheet support
- Default wire setting



E³.eCheck - DC Functional analysis and circuit checks for E³.series designs

Introduction

Zuken's E³.series is used for documenting and detailing electrical and fluid design projects. Its flexibility supports the entire design process from definition and design, through manufacturing and maintenance. Its unique object-oriented architecture ensures that all stages of the design are fully synchronized.

E³.eCheck is an extension to E³.series that enables users to functionally analyse their electrical schematic circuits and check designs for fuse and wire sizing errors. The utility works in real-time and provides instant feedback on the operability of the circuit design.

Supported industries

E³.eCheck is ideally suited to those working with DC control systems, such as transportation companies. Industries already served by E³.series include automotive, aerospace, railway, off-highway and special purpose vehicle.

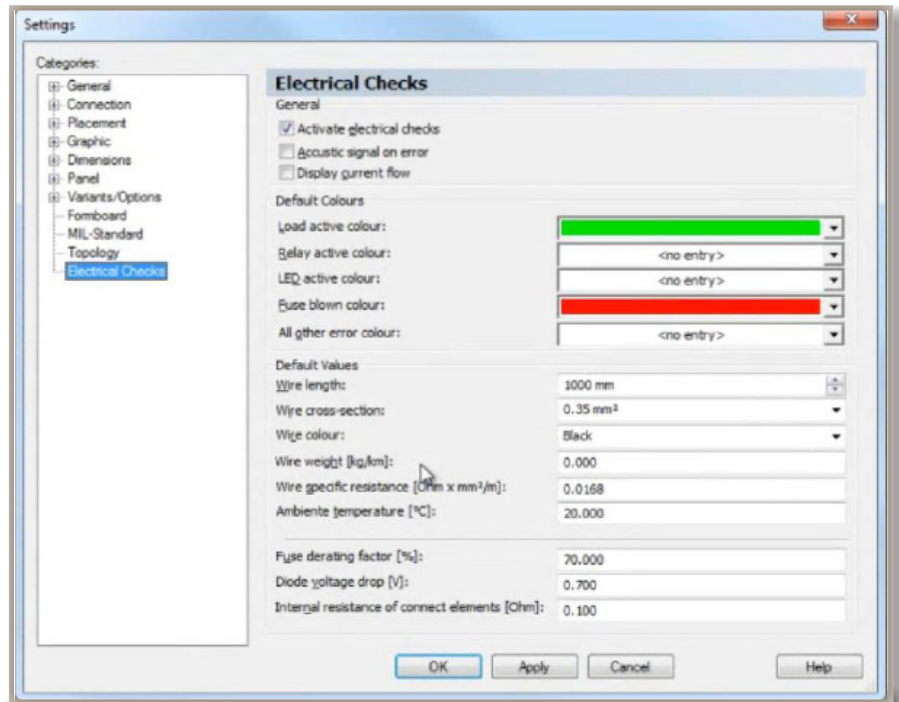

Default parameter and wire settings

Functionally-intelligent objects

In order to facilitate the functional checks special objects exist in the E³.series library, including power sources, fuses, switches, complex devices and loads. Power supplies allow the user to stimulate the circuit while fuses monitor the inline current. Switches can be activated allowing current to pass between their contacts, and complex devices such as relays are configured to open or close auxiliary contacts based on the coil operation.

Circuit analysis

Switches and contacts within the design are controlled by the voltage and current passing through the circuit. Energizing a coil will open and close auxiliary contacts, which in turn enables or disables current flow in other sections of the design simulating the real-life operation of the circuit. As current passes through to the load, objects such as lamps or motors voltage are checked and success or failure information is fed back to the user.

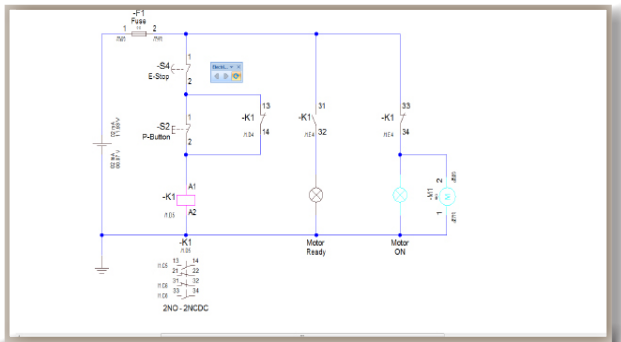

Latching relay circuit

Tolerance checks

During the analysis and design phase the current value and direction is constantly monitored at pin level. Voltage drop is monitored at each pin to determine the effectivity of the circuit. Inline fuses will fail should their tolerance be exceeded. Additionally, wires will fail if the current exceeds specified safety levels. This allows users to correct designs during the prototype or development phase – long before products enter the manufacturing stage.

Design for manufacture

E³.eCheck complements the comprehensive capabilities of E³.series. With its electrically-aware component library, specifically-designed kernel and numerous design rule checks, it is optimized for electrical design. Connector mates, connector pin terminals and cavity seals are automatically assigned and short-circuits and incorrect part usage is prevented, ensuring that correct design data is always available for manufacturing.

Additional E³.series options

E³.schematic

The core module of the E³.series suite enables the creation of schematic diagrams for electrical control systems.

E³.cable

Enhanced functionality for designing cables and cable harnesses. Different views of the design enable specific documents to be created for production, start-up and service.

E³.panel

For general arrangement drawings of cabinet enclosures. Work in either 2D or 3D, place devices, cable ducts and mounting rails and prepare panels for manufacture.

E³.formboard

Creates build-to-print detailed 1:1 harness designs; linked dynamically to E³.cable drawings.

E³.Revision Management

Document all physical and graphical changes between

design iterations. Automatically produce engineering change order documentation.

E³.3D Routing Bridge

Transfer wire, cable and cable harness information to 3D M-CAD systems. After routing, the individual wire lengths can be transferred back to E³.series.

E³.topology

Evaluate system harnesses early in the design flow for factors such as length, weight and cost. Enables tradeoff analysis of harnesses and sub-harnesses to optimize manufacturing performance and cost.

E³.redliner

Mark up documents in a protected read-only copy of the design. Playback and jump to all recommended changes in the master design.

E³.view

View all E³.series projects and special viewer files with this free-of-charge viewer.